

# GUIDED EJECTOR BUSHINGS

## SOLID BRONZE

**M** CA954 Solid Bronze **H** 170 Brinell

### Inch Standard

 CAD insertion point

CATALOG NUMBER	Nominal Diameter	D +.0005 -.0000	H +.0005 -.0000	C +.000 -.001	M +.00 -.01	B	K	L +.00 -.03
GEB50	1/2	.5005	.7505	.7490	.853	1.00	.56	1.50
GEB75	3/4	.7505	1.1255	1.1240	1.302	1.00	.56	1.50
GEB87	7/8	.8755	1.2505	1.2490	1.427	1.00	.56	1.50
GEB100	1	1.0005	1.3755	1.3740	1.552	1.12	.62	1.75
GEB125	1-1/4	1.2505	1.6255	1.6240	1.802	1.12	.62	1.75
GEB150	1-1/2	1.5005	2.0005	1.9990	2.177	1.12	.62	1.75
GEB200	2	2.0005	2.5005	2.4990	2.687	1.62	.80	2.25

### Metric Standard

CATALOG NUMBER	D +.013 +.026	H +.01 -.00	C -.01 -.03	M +.00 -.13	B	K	L +.0 -.8
GEBD20	20	26	26	28	25	15	37
GEBD25	25	32	32	35	29	16	45
GEBD30	30	38	38	41	29	16	45

 **x** For custom Bushings, refer to the templates in section X.

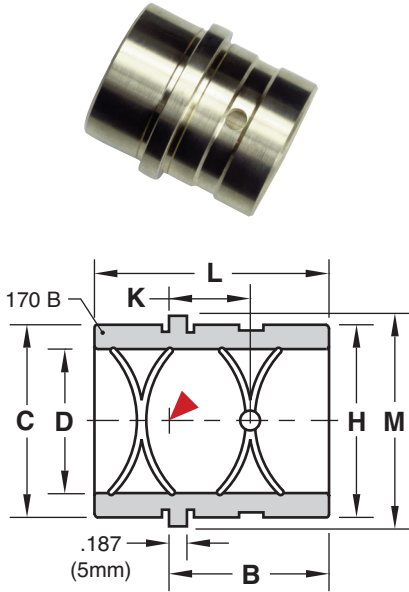

## GRAPHITE PLUGGED

**M** CA954 with oil impregnated graphite plugs **H** 170 Brinell

CATALOG NUMBER	Nominal Diameter	D +.0005 -.0000	H +.0005 -.0000	C +.000 -.001	M +.00 -.01	B	L +.00 -.03
GGP75	3/4	.751	1.1255	1.1240	1.302	1.00	1.50
GGP87	7/8	.876	1.2505	1.2490	1.427	1.00	1.50
GGP100	1	1.001	1.3755	1.3740	1.552	1.12	1.75
GGP125	1-1/4	1.251	1.6255	1.6240	1.802	1.12	1.75
GGP150	1-1/2	1.501	2.0005	1.9990	2.177	1.12	1.75
GGP200	2	2.001	2.5005	2.4990	2.687	1.62	2.25

Using grease will inhibit the function of the graphite plugs. Instead, use a light 20 weight oil at startup to begin lubrication.



## QC™ BUSHINGS

Liner: **M** CA954 **H** 170 Brinell

Body: **M** AISI 12L14 **H** 170 Brinell **S** Black Oxide

CATALOG NUMBER	Nominal Diameter	D +.0005 -.0000	H +.0005 -.0000	C +.000 -.001	M +.00 -.01	B	L +.000 -.015
GQC50	1/2	.5005	.7505	.7490	.853	1.00	1.50
GQC75	3/4	.7505	1.1255	1.1240	1.302	1.00	1.50
GQC87	7/8	.8755	1.2505	1.2490	1.427	1.00	1.50
GQC100	1	1.0005	1.3755	1.3740	1.552	1.12	1.75
GQC125	1-1/4	1.2505	1.6255	1.6240	1.802	1.12	1.75
GQC150	1-1/2	1.5005	2.0005	1.9990	2.177	1.12	1.75
GQC200	2	2.0005	2.5005	2.4990	2.687	1.62	2.25

Note: Replacement lubricating strips are available with pricing listed in the price list.

